

RF FLANGES: A/GS

FF FLANGES: B

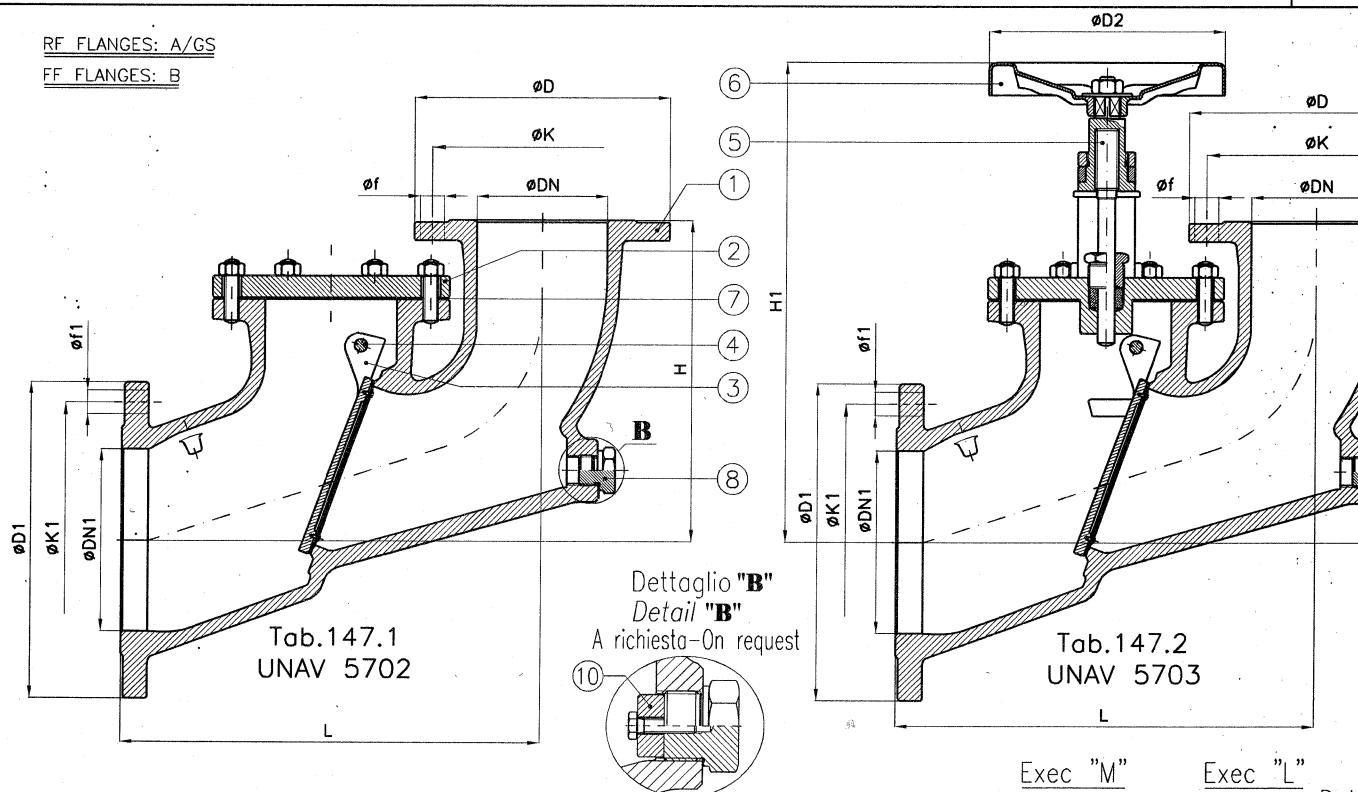

Tipo - Type	Caratteristiche - Specification
UNAV 5702	Senza bloccaggio Without geared for screw-down shut-off
UNAV 5703	Con sistema di bloccaggio e regolazione apertura Geared for screw-down shut-off

DN	DN1	D2	L	H (~)	H1 (~)	D	K	f	Holes No. f	D1	K1	f1	Holes No. f1	Tab147.1 Weight (Kg)	Tab147.2 Weight (Kg)
65	100	150	220	160	285	160	130	14	4	210	170	18	4	16	19
80	125	175	250	190	330	190	150	18	4	240	200	18	8	24	27
100	150	175	290	220	365	210	170	18	4	265	225	18	8	31	36
125	175	200	320	260	415	240	200	18	8	295	255	18	8	42	46
150	200	200	345	285	460	265	225	18	8	320	280	18	8	56	58
200	250	225	525	400	500	320	280	18	8	375	335	18	12	93	95
250	350	250	675	460	640	375	335	18	12	490	445	22	12	179	181
300	400	250	795	545	710	440	395	22	12	540	495	22	16	234	236

Exec "M"

Exec "L"

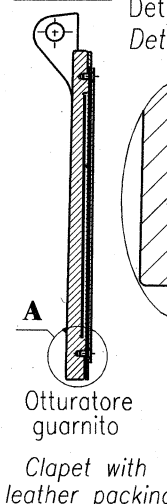
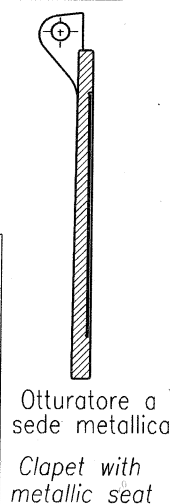

Combinazione materiali standard - Standard materials Combination

ITEM	DENOMINAZIONE DENOMINATION	A/316 MATERIALE MATERIAL	A/B MATERIALE MATERIAL	B/B MATERIALE MATERIAL	GS/316 MATERIALE MATERIAL	GS/B MATERIALE MATERIAL
01	Body	Cast steel GP240-GH UNI EN10213	Cast steel GP240-GH UNI EN10213	Bronze UNI EN1982 G-CuSn5Zn5Pb5	Nodular cast iron EN-GJS-400-15U UNI EN1563	Nodular cast iron EN-GJS-400-15U UNI EN1563
02	Bonnet	Cast steel GP240-GH UNI EN10213	Cast steel GP240-GH UNI EN10213	Bronze UNI EN1982 G-CuSn5Zn5Pb5	Nodular cast iron EN-GJS-400-15U UNI EN1563	Nodular cast iron EN-GJS-400-15U UNI EN1563
03	Disc	Stainless steel AISI316 UNI EN10088	Bronze UNI EN1982 G-CuSn5Zn5Pb5	Bronze UNI EN1982 G-CuSn5Zn5Pb5	Stainless steel AISI316 UNI EN10088	Bronze UNI EN1982 G-CuSn5Zn5Pb5
04	Pin	Stainless steel AISI316 UNI EN10088	Stainless steel AISI316 UNI EN10088	Stainless steel AISI316 UNI EN10088	Stainless steel AISI316 UNI EN10088	Stainless steel AISI316 UNI EN10088
05	Stem	Stainless steel AISI316 UNI EN10088	Brass CW617N (OT58)	Brass CW617N (OT58)	Stainless steel AISI316 UNI EN10088	Brass CW617N (OT58)
06	Handwheel	Sheet of carbon steel	Sheet of carbon steel	Sheet of carbon steel	Sheet of carbon steel	Sheet of carbon steel
07	Gasket	EPDM	EPDM	EPDM	EPDM	EPDM
08	Plug	Brass CW617N (OT58)	Brass CW617N (OT58)	Brass CW617N (OT58)	Brass CW617N (OT58)	Brass CW617N (OT58)
09	Disc seat	Metallic/leather packing	Metallic/leather packing	Metallic/leather packing	Metallic/leather packing	Metallic/leather packing
10	Sacrificial anode (>ND150)	ZINC	ZINC	ZINC	ZINC	ZINC

Nota: Combinazioni materiali non standard a richiesta

Note: Non standard materials combinations on request